

Архангельск (8182)63-90-72
Астана (7172)727-132
Астрахань (8512)99-46-04
Барнаул (3852)73-04-60
Белгород (4722)40-23-64
Брянск (4832)59-03-52
Владивосток (423)249-28-31
Волгоград (844)278-03-48
Вологда (8172)26-41-59
Воронеж (473)204-51-73
Екатеринбург (343)384-55-89
Иваново (4932)77-34-06

Ижевск (3412)26-03-58
Иркутск (395)279-98-46
Казань (843)206-01-48
Калининград (4012)72-03-81
Калуга (4842)92-23-67
Кемерово (3842)65-04-62
Киров (8332)68-02-04
Краснодар (861)203-40-90
Красноярск (391)204-63-61
Курск (4712)77-13-04
Липецк (4742)52-20-81
Киргизия (996)312-96-26-47

Магнитогорск (3519)55-03-13
Москва (495)268-04-70
Мурманск (8152)59-64-93
Набережные Челны (8552)20-53-41
Нижний Новгород (831)429-08-12
Новокузнецк (3843)20-46-81
Новосибирск (383)227-86-73
Омск (3812)21-46-40
Орел (4862)44-53-42
Оренбург (3532)37-68-04
Пенза (8412)22-31-16
Казахстан (772)734-952-31

Пермь (342)205-81-47
Ростов-на-Дону (863)308-18-15
Рязань (4912)46-61-64
Самара (846)206-03-16
Санкт-Петербург (812)309-46-40
Саратов (845)249-38-78
Севастополь (8692)22-31-93
Симферополь (3652)67-13-56
Смоленск (4812)29-41-54
Сочи (862)225-72-31
Ставрополь (8652)20-65-13
Таджикистан (992)427-82-92-69

Сургут (3462)77-98-35
Тверь (4822)63-31-35
Томск (3822)98-41-53
Тула (4872)74-02-29
Тюмень (3452)66-21-18
Ульяновск (8422)24-23-59
Уфа (347)229-48-12
Хабаровск (4212)92-98-04
Челябинск (351)202-03-61
Череповец (8202)49-02-64
Ярославль (4852)69-52-93

<https://tsurumi.nt-rt.ru/> || tmy@nt-rt.ru

SERIES PNI

SUBMERSIBLE
RESIN MADE PUMPS





Submersible Resin Made Wastewater Pumps

Tsurumi's PNI-series of submersible wastewater pumps are made of resin and stainless steel, which makes them compact, lightweight and easy to handle. The pumps feature an energy-saving design that reduces power consumption by approx. 20% in comparison with competitor pumps of equivalent output class.

The combination of resin and stainless steel provides excellent durability and corrosion resistance regardless of the lightweight body. And, the resin material used for these pumps is selected for the relevant parts. Therefore, the PNI-series is more advantageous in terms of durability and corrosion resistance than simple resin pumps.

Furthermore, PNI-series pumps are so compact that they can be easily installed in limited/cramped spaces such as inside septic tanks/Johkasou and wastewater tanks of small-scale wastewater treatment facilities, and wastewater tanks under home and building kitchens. In addition, because the PNI-series uses food-grade liquid paraffin for lubricating oil, these pumps are safe and fish-friendly if used for water circulation and water features in carp/koi ponds, fish farms, waterfalls, etc.

Tsurumi's PNI product lineup also includes an AUTO type with a bell-shaped float switch that enables automatic operation. This float switch can change pump operation between manual and auto modes. Using a magnet incorporated in the float switch, pump operation is automatically controlled according to the rise or fall in water level. And, since the float moves only up/down, the pump can work in limited installation space, and rarely malfunctions even in wastewater containing oil. Users can adjust the water level at which the pump starts and stops, by adjusting the float position with a screwdriver. In comparison with pumps using a general float, this model enables drainage at lower water level.

Original technologies that Tsurumi has accumulated through research and proven in the market are integrated into the compact body of the PNI-series pumps, e.g., an anti-wicking cable*, dual inside mechanical seals with silicone carbide face and an Oil Lifter. (* Except for AUTO type)

Tsurumi, as a pioneer of resin pumps, has researched designs that enable continuous duty for many years, while pursuing pump durability and maintainability. Thanks to these technologies, Tsurumi pumps ensure stable quality and safety, thus inspiring more confidence in use.



Model
50PNI2.4S

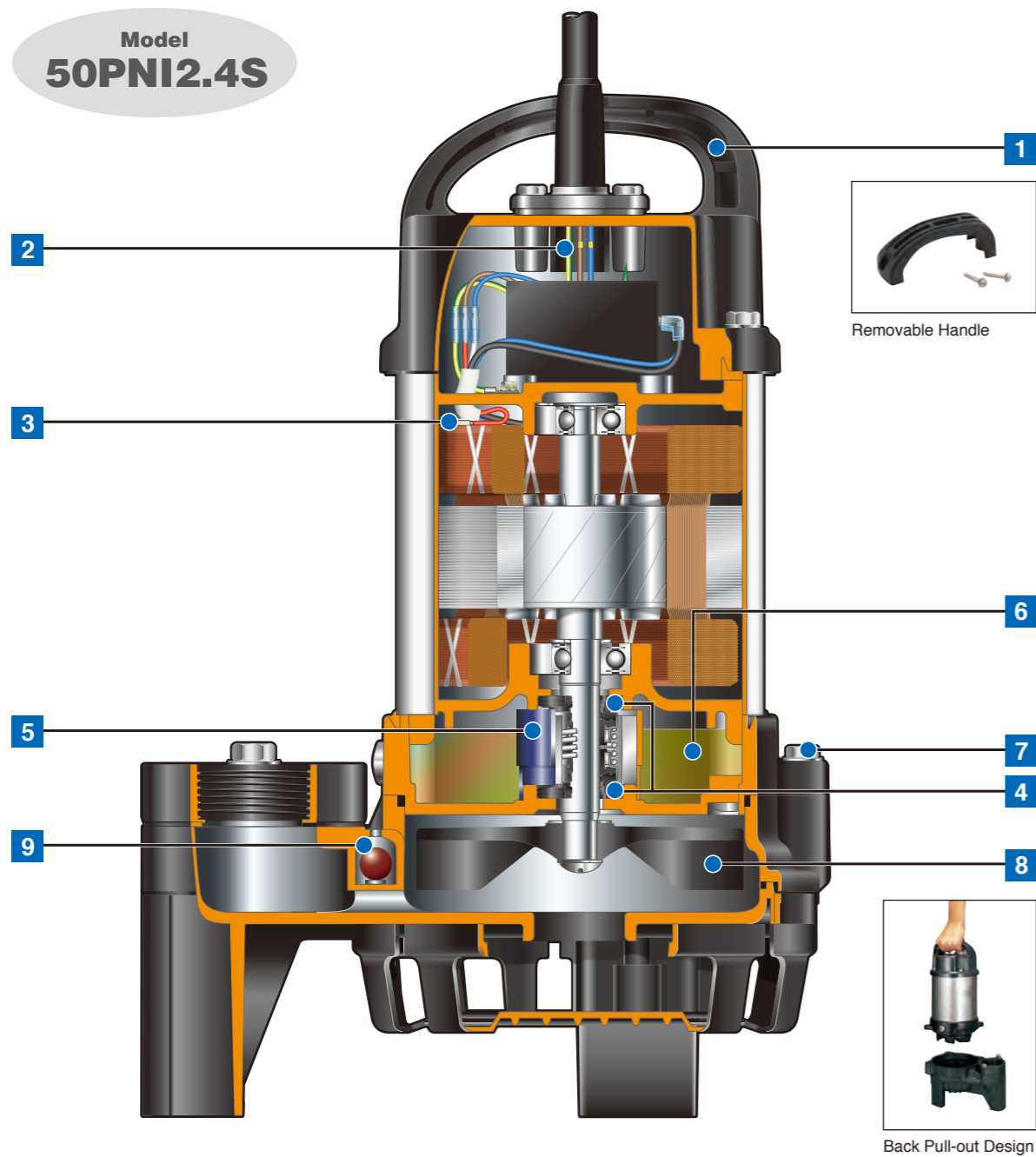

Special Resin

The resin used for the PNI-series is not simple resin, but special resins produced by applying advanced treatment to elaborate compound material. Each pump component is made of resin that has been compounded at the optimum ratio for the role of the relevant parts. Therefore, the PNI-series is more advantageous in terms of durability and corrosion resistance than simple resin pumps.

PPS-(MD+GF)50 - Excellent heat resistance and chemical resistance, and high mechanical strength

PPO-GF20 - Water-proofing, and resistance to acids and alkalis

ABS-GF20 - Excellent impact resistance, water-proofing, and resistance to acids and alkalis

ABS - Excellent impact resistance, water-proofing, and resistance to acids and alkalis



1 Removable Handle

Since the handle can be separated from the head cover, just the handle itself can be replaced.

2 Anti-wicking Cable Entry

* Not available on AUTO type

Prevents water incursion due to capillary action should the cable sheath be damaged or the end of cable submerged. Also prevents moist air from infiltrating the motor housing and condensation from forming inside the housing due to temperature differences between the housing and outside air.

3 Motor Protector

Miniature Thermal Protector (0.4kW)

Detects excess heat, therefore, protecting the pump against overheating and dry-running.

Circle Thermal Protector (0.75kW)

Directly cuts the motor circuit if excessive heat builds up or overcurrent occurs in the motor.

4 Dual Inside Mechanical Seals with Silicon Carbide Face

Isolated in the oil chamber where a clean, non-corrosive and abrasion-free lubricating environment is maintained. Compared with the water-cooled outside mechanical seal, it reduces the risk of failure caused by dry-heating and adhering matter. The silicon carbide provides 5 times higher corrosion, wear and heat resistance than the tungsten carbide.

5 Oil Lifter

Provides lubrication and cooling of the seal faces down to 1/3 of normal oil level, thus maintaining a stable shaft sealing effect and prolonging seal life longer. The Oil Lifter is Tsurumi original design.

6 Liquid Paraffin Oil

This high-purity oil is commonly used in the cosmetics, pharmaceuticals and food processing equipment. Because it is a food grade lubricant, the pump can be safely used for water features in carp/koi ponds and fish farms.

7 Back Pull-out Design

Enables the motor to be separated from the pump unit with the impeller attached, by removing the bolts between the oil casing and the pump casing. This design facilitates maintenance and inspection of the principal parts of the pump.

8 Resin Semi-vortex Impeller

Resists wear caused by abrasive particles and enables the pump to maintain its original performance for an extended period of time.

9 Air Release Valve

Fitted into the pump casing to prevent the air lock. When air flows through the valve, the ball stays at the bottom, but when the pumped water starts to flow, the ball closes the outlet because of its buoyancy.

PNI

PNI (AUTO)



0.4kW

0.75kW



0.4kW

0.75kW

Performance Curves

Standard and Automatic Models have the identical performance.

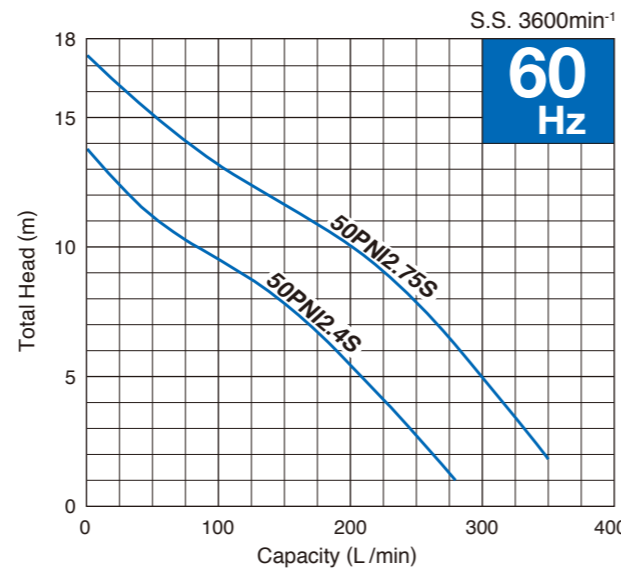
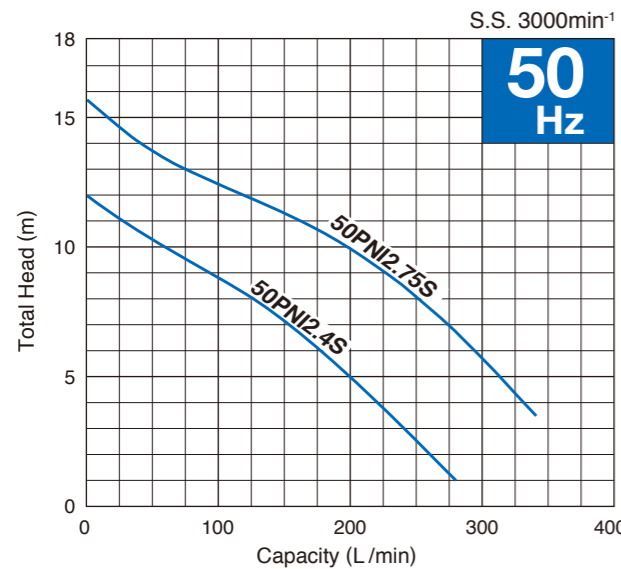

Specifications

		50PNI2.4S	50PNI2.75S
		50PNI2.4S (AUTO)	50PNI2.75S (AUTO)
PUMP	Discharge Bore	50 mm	
	Discharge Connection	Threaded Oval Flange	
	Solids Passage	10 mm	
	Impeller	Semi-vortex / Glass-fiber Reinforced Resin (PPO-GF20)	
	Casing	Glass-fiber Reinforced Resin (Upper: ABS-GF20 / Lower: ABS)	
	Shaft Seal	Dual Inside Mechanical Seals (with Oil Lifter) / Silicon Carbide	
MOTOR	Type / Pole	Dry-type Submersible Induction Motor / 2-pole	
	Output	0.4 kW	0.75 kW
	Phase	Single	
	Insulation	E	
	Starting Method	Capacitor Run	
	Motor Protector (built-in)	Miniature Thermal Protector	Circle Thermal Protector
	Lubricant	240 ml / Liquid Paraffin (ISO VG32)	
	Frame	304 Stainless Steel	
	Shaft	403 Stainless Steel	
	Cable	5 m / PVC	
Dimensions L x W x H		241 x 162 x 360 mm 241 x 246 x 365 mm (AUTO)	241 x 162 x 380 mm 241 x 246 x 385 mm (AUTO)
Dry Weight (excluding Cable)		7.2 kg 7.4 kg (AUTO)	9.3 kg 9.5 kg (AUTO)

AUTO Type – Automatic Operation

- Automatic and manual operation modes can be changed over with a single switch.
- The bell-shaped float moves only up/down, so this pump is suitable for installation in limited/cramped places.
- This model enables drainage at lower water levels than pumps with a float for general start/stop water level.
- With the adjustable float switch, this pump can work at a water level suitable for field conditions.
- The possibility of float malfunction is low, even in wastewater containing a certain amount of oil.

Automatic Operation

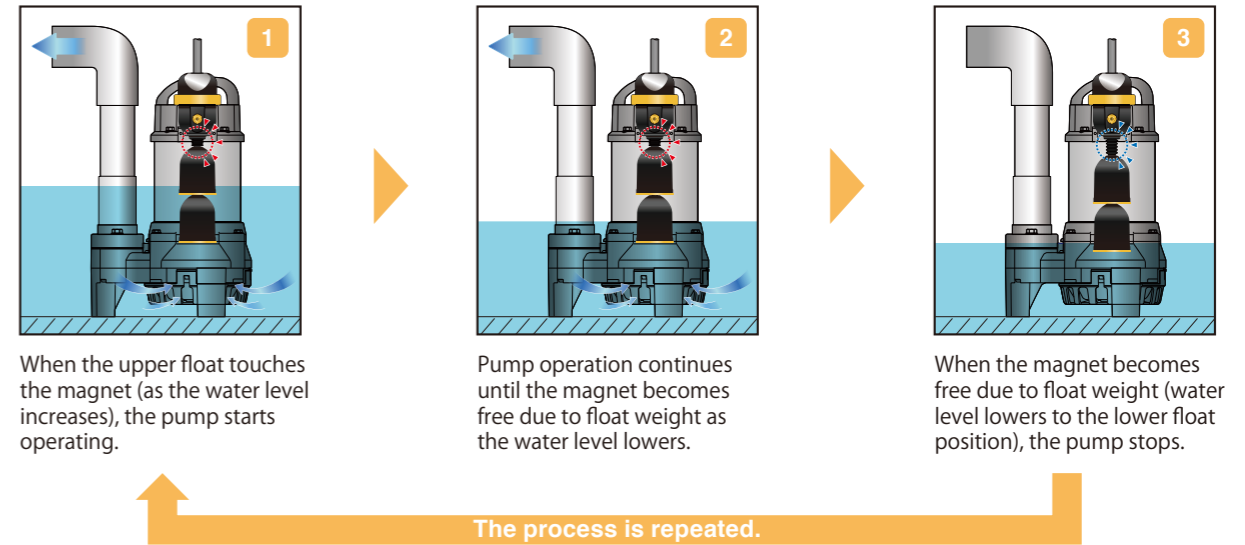

Installation in Limited/Cramped Space

The bell-shaped float moves only up/down, so the pump enables drainage in limited/cramped space and at a low water level. Since the float does not oscillate right/left, the possibility of malfunction is reduced.

Adjustable Float Switch

The position of the bell-shaped float can be adjusted easily with a screwdriver. Users can adjust the start/stop water level to field conditions.

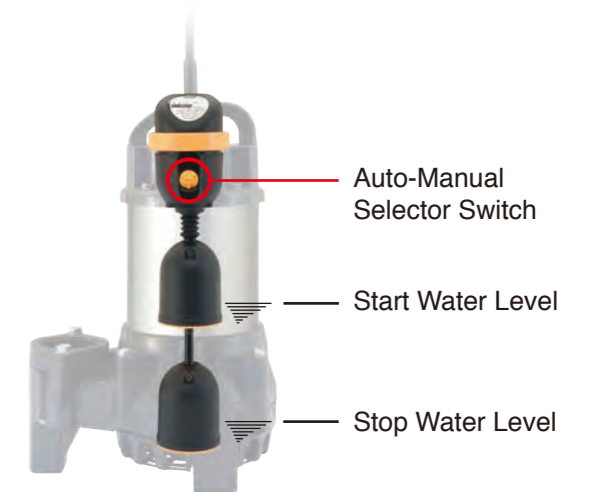

Drainage of Wastewater Containing Oil

With a cylindrical float, oil contained in inflow water becomes greasy, whereby causing pumps to malfunction. However, with the bell-shaped float, the above phenomenon does not occur, so the pump rarely malfunctions even in wastewater containing a certain amount of oil or household wastewater.



Архангельск (8182)63-90-72
Астана (7172)727-132
Астрахань (8512)99-46-04
Барнаул (3852)73-04-60
Белгород (4722)40-23-64
Брянск (4832)59-03-52
Владивосток (423)249-28-31
Волгоград (844)278-03-48
Вологда (8172)26-41-59
Воронеж (473)204-51-73
Екатеринбург (343)384-55-89
Иваново (4932)77-34-06

Ижевск (3412)26-03-58
Иркутск (395)279-98-46
Казань (843)206-01-48
Калининград (4012)72-03-81
Калуга (4842)92-23-67
Кемерово (3842)65-04-62
Киров (8332)68-02-04
Краснодар (861)203-40-90
Красноярск (391)204-63-61
Курск (4712)77-13-04
Липецк (4742)52-20-81
Киргизия (996)312-96-26-47

Магнитогорск (3519)55-03-13
Москва (495)268-04-70
Мурманск (8152)59-64-93
Набережные Челны (8552)20-53-41
Нижний Новгород (831)429-08-12
Новокузнецк (3843)20-46-81
Новосибирск (383)227-86-73
Омск (3812)21-46-40
Орел (4862)44-53-42
Оренбург (3532)37-68-04
Пенза (8412)22-31-16
Казахстан (772)734-952-31

Пермь (342)205-81-47
Ростов-на-Дону (863)308-18-15
Рязань (4912)46-61-64
Самара (846)206-03-16
Санкт-Петербург (812)309-46-40
Саратов (845)249-38-78
Севастополь (8692)22-31-93
Симферополь (3652)67-13-56
Смоленск (4812)29-41-54
Сочи (862)225-72-31
Ставрополь (8652)20-65-13
Таджикистан (992)427-82-92-69

Сургут (3462)77-98-35
Тверь (4822)63-31-35
Томск (3822)98-41-53
Тула (4872)74-02-29
Тюмень (3452)66-21-18
Ульяновск (8422)24-23-59
Уфа (347)229-48-12
Хабаровск (4212)92-98-04
Челябинск (351)202-03-61
Череповец (8202)49-02-64
Ярославль (4852)69-52-93

<https://tsurumi.nt-rt.ru/> || tmy@nt-rt.ru